

SMART VENDING MACHINE (SVM)



SA-NETWORK LIMITED



Table of Contents

About Us

New Retail Business Model

Automatic Hot & Cold Vending Machine

Ice Cream Vending Machine

Hot and Iced Drinks Vending
Machine

Omni Channel Retail Platform

Contact Details

About Us

SA-Network Limited

SA-Network Limited is a UK subsidiary of VEI, Hong Kong's leading provider of cutting-edge vending solutions. We specialize in the development and deployment of advanced vending machines that go beyond traditional product dispensing. Our machines are equipped with high-definition screens that can display advertisements, promotional videos, and interactive content, enhancing the overall shopping experience.

New Retail Business Model

New Retail Style
from “Service” to
“Self-Service”

Unmanned Store

Fully Automatic
Service

7x24x365

Big/Middle/Small
Advertising Monitor
(New/Potential
Advertising Income)

Different Essential
Products &
Different SVMs

Low Operational
Cost

Low Investment &
High Return

Completed
Business Solution

Verified by New
Retail Business
Model

Franchise

AUTOMATIC HOT & COLD VENDING MACHINE



Product Features

- Smart monitoring with Single Row & Column opening to make sure that the products are safe during the delivery process
- 3 Different sizes and 10 rows of pick-up cargo lanes (Max. 120 Qty of items)
- Double-layer of tempered electric heating with an anti-fog glass
- Temperature control (5-65°C)
- Monitors the product delivery process and the location opening status
- Supports automatic disinfection to ensure the safety of products
- 7*24 safety remote support with network terminal management
- Supports multiple pick-up verification methods, including Online and Offline Self-Service
- Supports the multimedia Ads and announcement carousel playlist with images and videos
- Supports invoicing cloud backend management system
- Supports multiple electronic payment methods to reduce the possibility of virus infection
- 3 Different sizes of cargo lanes
- The number of cargo lanes from left to right: 40, 80, 120
- The maximum product height is 95mm

SVM - SPECIFICATION

**AUTOMATIC HOT & COLD
VENDING MACHINE (5°C – 65°C)**



Automatic Hot & Cold
(5°C - 65°C)

Payment Method
Octopus / T300U

Dimension
H= 1,855mm
W= 1,000mm
D= 880mm

Internet Connection
4G / WIFI / Lan

Power Spec
About 310 KG
220V AC
50Hz
2Kw Max Power
10A

OS System
Android

SVM - Size

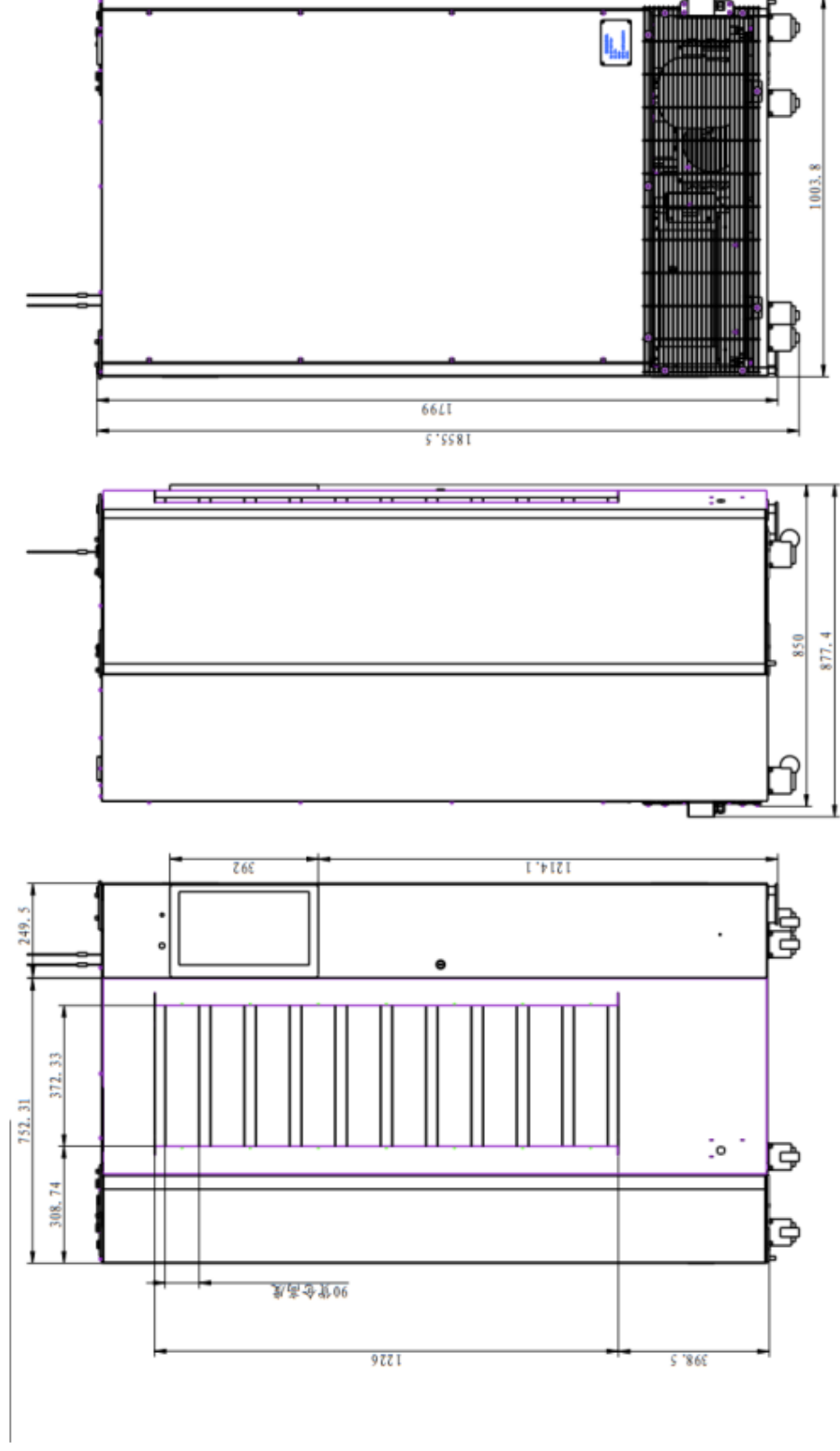

Automatic Hot & Cold Vending Machine

ICE CREAM VENDING MACHINE



Product Features

- 43" Touch Screen Monitor
- Temperature Control (-23 - 0°C)
- Separate Temperature Control System
- Two different sizes of cargo lanes (Cup or Stick)
- Provides a fast and convenient self-service shopping guide in a touchscreen mode
- Support to monitor the product delivery inspection and opening status
- Support Cloud Backend Management System to check the sales transactions in 7x24
- Support multiple electronic payment methods to reduce the possibility of virus infection
- The innovative design of SVM - Ice Cream is well-completed and released to the market in 2017. A total of 1000+ units have been sold out and promoted to well-known large supermarket chains and cinemas
- Suitable for packaging frozen foods such as ice cream cup and stick
- Separate Temperature Control System, no defrost cycle
- The machine has an excellent preservation performance, which can effectively keep cold for 9 hours in case if the power supply suspension will happen

SVM - SPECIFICATION

ICE CREAM VENDING MACHINE (-23°C - 0°C)

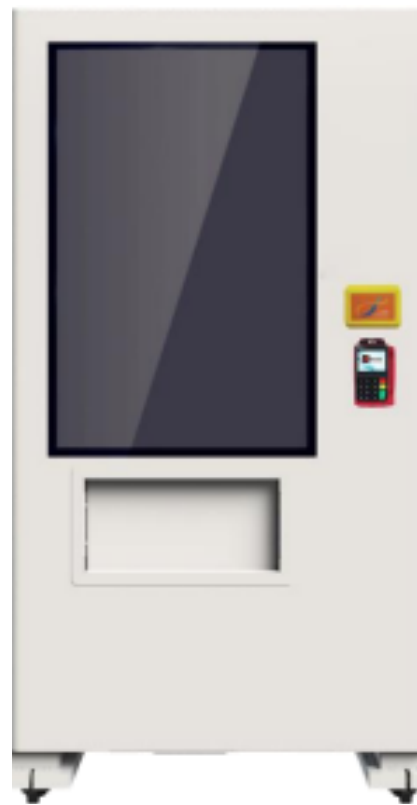

Freeze (-23°C - 0°C)

Dimension

H= 1,860mm

W= 1,025mm

D= 916mm

Power Spec

About 247 KG

220V AC

50-60Hz

1.1Kw Max Power

5A

Payment Method

Octopus/ T300U

Internet Connection

4G / WIFI / Lan

OS System

Window/ Android

SVM - Size

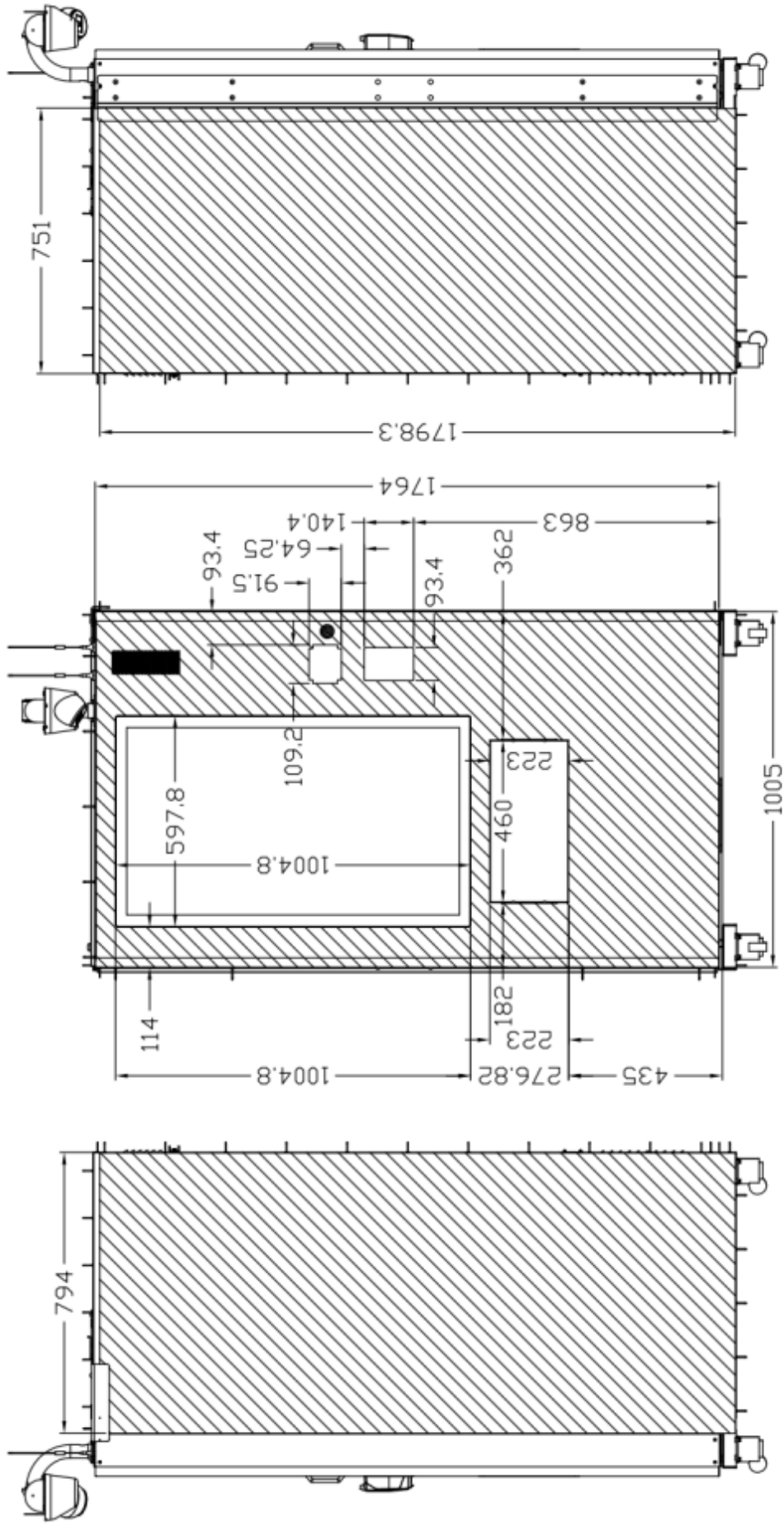

Ice Cream Vending Machine

HOT AND ICED DRINKS VENDING MACHINE

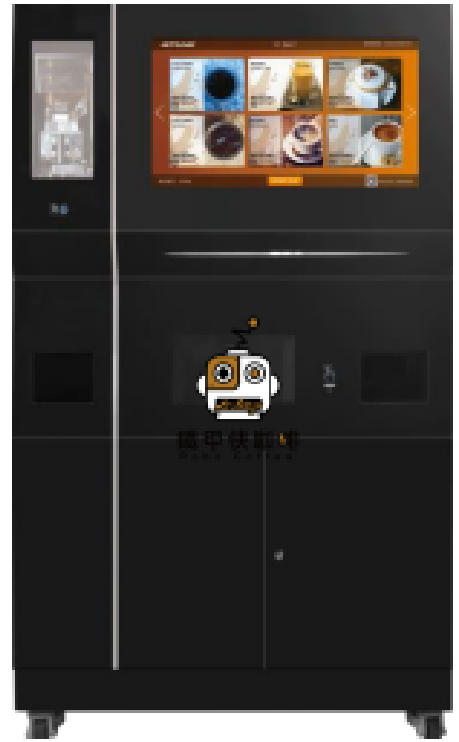

Product Features

- Provides Hot Drinks, Iced Drinks and Bag-in-Box packaging (BIB) Drinks for multiple choices in different seasons
- Ground Coffee, Cappuccino, Latte, Mocha, Chocolate, Tea and Healthy Drinks are the selected options for drinks
- Starts with one button to make a DIY high-quality hot drink within 45 seconds for one transaction (Iced Drinks 90 seconds)
- Provides storage for placing the drink sticks to upgrade the taste of the drink

SVM - SPECIFICATION

HOT & ICED DRINKS VENDING MACHINE

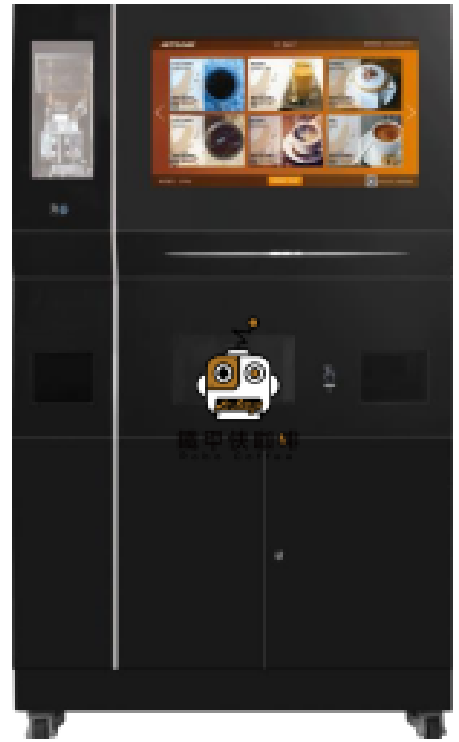

Hot & Iced Coffee
Healthy Drinks (BIB)

Dimension
H= 1,855mm
W= 1,000mm
D= 785mm

Power Spec
About 250 KG
220-240V AC
50/60Hz
2.7Kw Max Power
10-16A

Payment Method
Octopus / T300U

Internet Connection
4G / WIFI

OS System
Android

SVM - Size

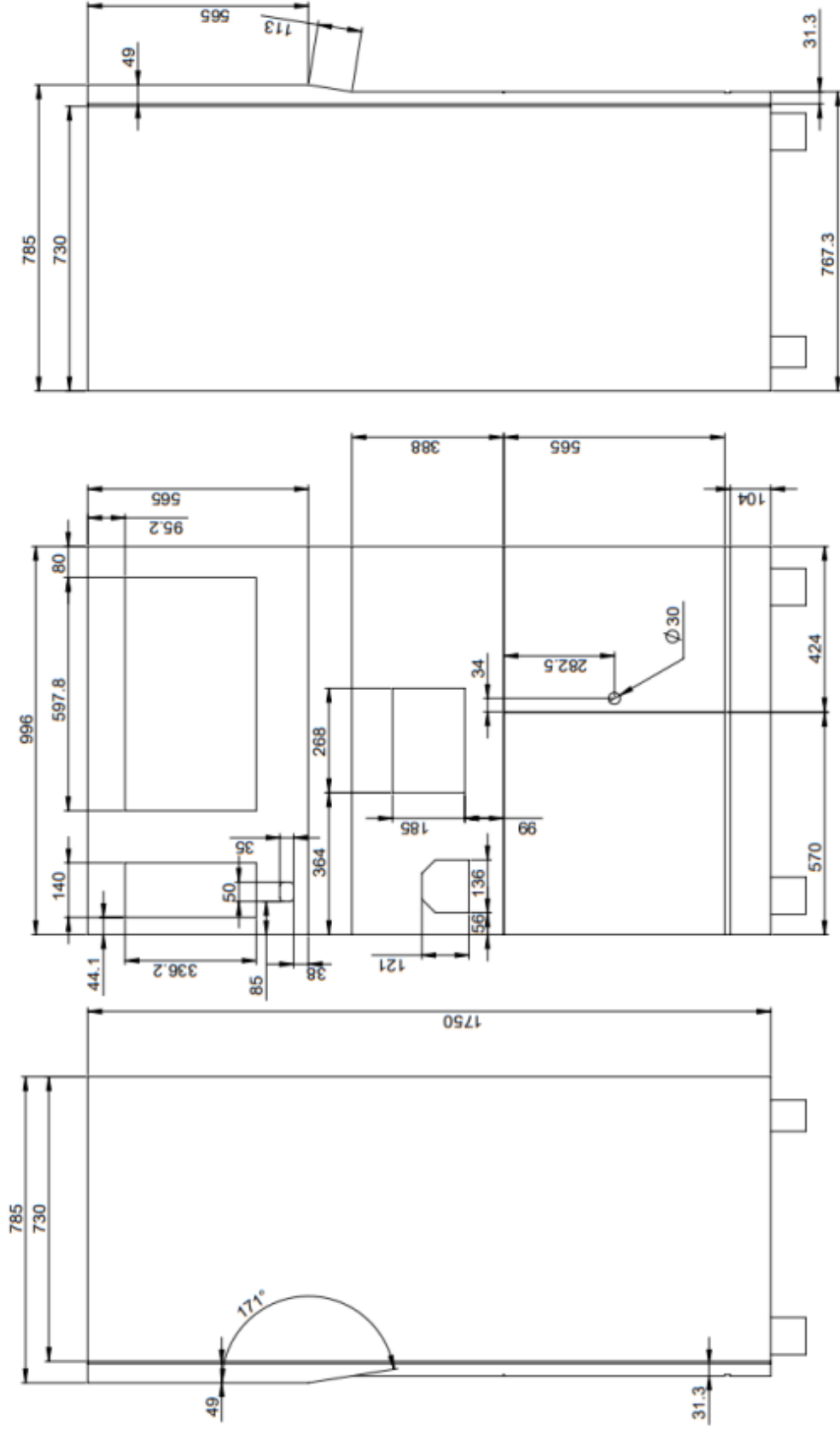

Hot & Iced Drinks Vending
Machine

Retail ONE

Omni-Channel Retail Platform

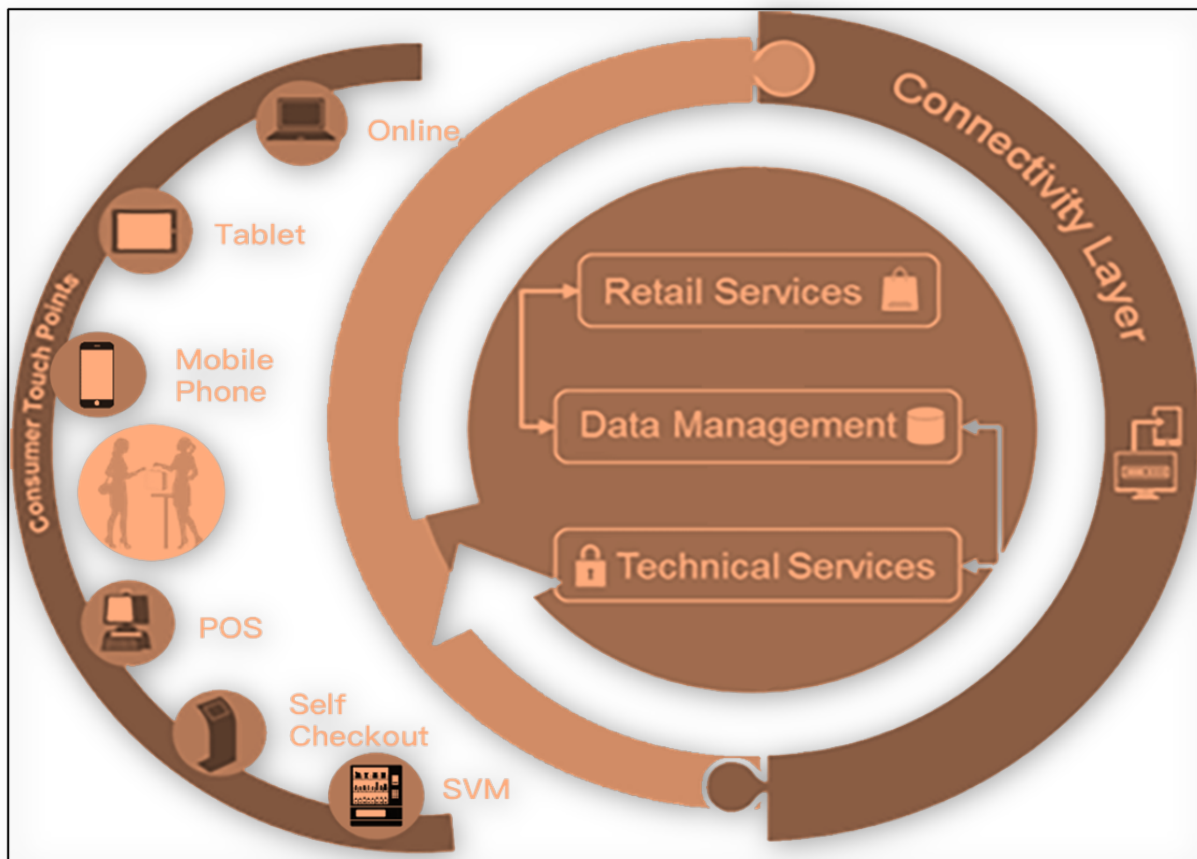

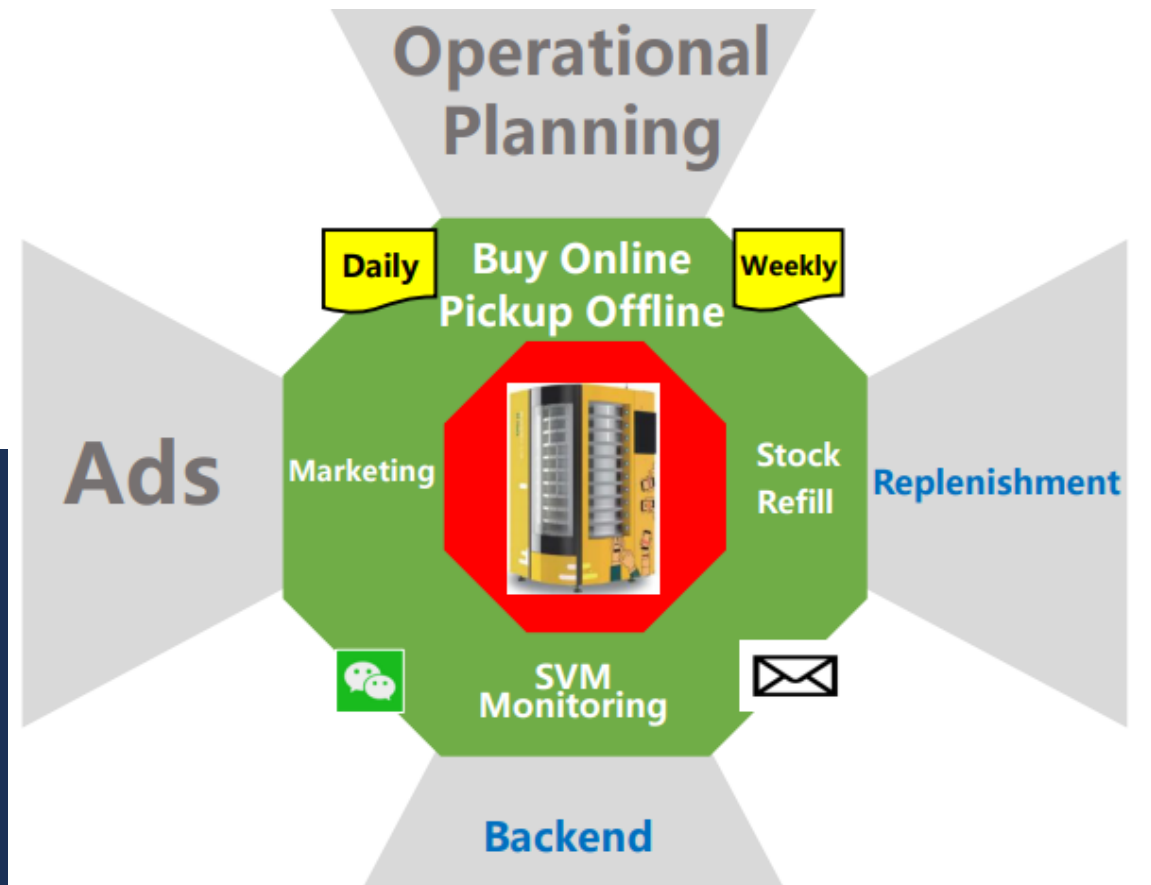

Perfect Retail Solution with Professional and High-Quality Services

1. Selling Mode – Two Standard Methods
 - Order Via SVM
 - Order Via Online + Pick Up Via SVM (O2O)
 - Buy multiple items in one transaction, then pick up once together

2. Stock Management
 - Inventory Management with Centralized Control Systems
 - Email / WeChat - Notification of Low Stock Level

3. 24/7 Monitoring of SVM Health Status

4. Facial Recognition / User Behavior Analysis

LET'S WORK TOGETHER



+44 (0) 7442 238067
+852 2950 4288
+86 020-8303 3128



allsales@value-exch.com



1804 Skyline Apartments 11 Makers Yard,
London, England E3 3YL

SA-Network Limited

© Value Exchange International Limited, all rights reserved 2023.